



**INSTALLATION INSTRUCTIONS
FOR
PRO-16 S3
6 CHANNEL
CAPACITOR DISCHARGE
IGNITION**

PLEASE REPORT ANY OMISSIONS OR
ERRORS TO SALES@MWIGNITIONS.COM

CONTENTS:

1. Installation notes
2. Ignition coil information
3. Mounting dimensions
4. Connections and specifications
5. 6 channel direct fire ignition
6. 6 coil wasted spark ignition
7. Mazda triple rotor ignition

CAUTION

**THIS WIRING DIAGRAM IS
APPLICABLE ONLY TO
IGNITION SYSTEMS WITH THE
SERIAL NUMBER PREFIX
STARTING**

38xxxx

**INCORRECT INSTALLATION
WILL VOID WARRANTY**

IMPORTANT **INSTALLATION NOTES**

MOUNTING

Do not mount the unit where it will be exposed to water
Do not mount near excessively hot engine components
Use rubber mounts to isolate from strong vibration
Where possible provide a cooling air supply
Mount with the connector end low

IGNITION LEADS & SPARKPLUGS

Do not use straight wire high tension leads
Do not use carbon suppressed high tension leads
Use premium quality spiral wound metal core leads
Do not use resistor type spark plugs

POWER SUPPLY

Do not use a power supply above 16V
Do not solder connector terminals
Do not use a 'voltage booster'
Connect the cdi directly to the battery

LED INDICATOR

Once the unit has been switched on the led will illuminate for approximately 1 second and then extinguish. Each consecutive trigger input will be indicated by a single short flash. A repeated double flash indicates the generator stage has been unable to reach correct operating voltage.

IGNITION COILS

CAUTION

IGNITION COILS MAY BE DAMAGED INTERNALLY IF ALLOWED TO FIRE WITHOUT A SPARKPLUG AND HT LEAD INSTALLED.

If your engine develops a misfire which can not be eliminated by other means try replacing the ignition coil on the suspect cylinder with one that is known to be good.

COP coils with in built drivers are not suitable for cdi applications. Small COP ignition coils may overheat when used with a cdi system unless wired in parallel for wasted spark applications.

Most ignition coils will work with CDI system however for best power select one with very low resistance and inductance with a turns ration between 75 and 100 to 1.

FERRITE COILS

Be aware when buying ferrite coils from other suppliers as not all companies have the knowledge to correctly prepare them for automotive use. Due to their fragile nature and poor quality control during manufacture it is easy to experience premature ignition coil failure and engine misfiring unless correctly assembled. All coils prepared by M&W are individually tested before assembly and sale.

**CAUTION!
HIGH VOLTAGE**



**DISCONNECT POWER BEFORE
WORKING ON UNIT**

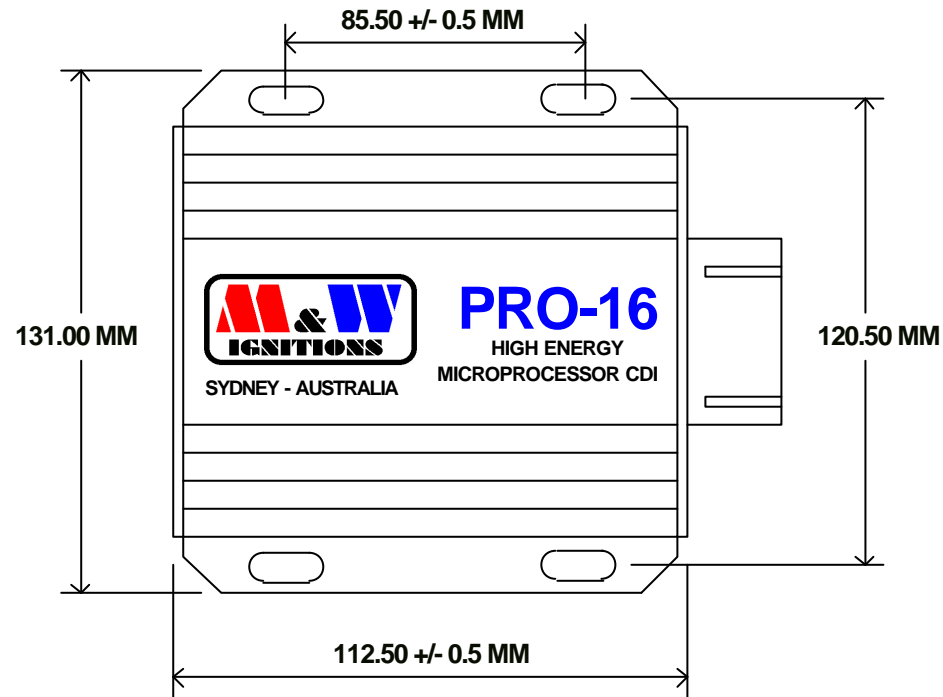

Slot dimensions - 5mm * 10mm

Title		MOUNTING DIMENSIONS	
Size	Number	Revision	
A4	PRO-16 SERIES 3	1.0	
Date:	18-Apr-2006	Sheet 1 of	1
File:	D:\M&W\Pro16_S3_Mounting dimensions.s	Drawn By:	M&W

**CAUTION!
HIGH VOLTAGE**



DISCONNECT POWER BEFORE
WORKING ON UNIT

M & W IGNITIONS

(C)1996 - 2006 M&W IGNITIONS

POWER LEVEL SELECTION

105mJ - leave pin #13 disconnected.
150mJ - connect pin #13 to pin #10.

TRIGGER EDGE SELECTION

Falling edge ignition - leave pin #9 disconnected.
Rising edge ignition - connect pin #9 to pin #10.
When triggering this unit of an existing ignition module or an ecu with built in igniters such as the Microtech 'MTX' series it may be necessary to select rising edge trigger.

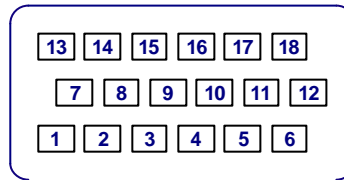

CDI CONNECTOR
(LOOKING AT END
OF EXTRUSION)

SPECIFICATIONS

Supply voltage = 13.8V DC negative ground
Operating voltage = +5.5V to +15V
Maximum supply current = 6.0A (per unit)
Power off current < 700uA
Maximum ignition frequency = 1200/800 Hz (combined)
Coil primary voltage = 460V/540V
Spark energy = 105/150 millijoules
Trigger = 10mA adjustable edge
Tacho = 12V, 25mA square wave
Maximum allowable case temperature = 105°C
Dimensions = 112L * 110W * 40H
Weight = 570gm (each)

KEEP ALL INPUTS WELL SEPARATED FROM COIL OUTPUTS

1 +12V (Battery)	7 Ground (Battery)	13 Power level
2 +12V (Battery)	8 Ground (Battery)	14 Triggers C & D
3 Triggers E & F	9 Trigger edge	15 Triggers A & B
4 Tacho	10 Signal ground	16 Ignition switch
5 Coils E & F +	11 Coils C & D +	17 Coils C & D -
6 Coils A & B +	12	18 Coils A/C & B/D -

Title			
PRO-16 SIX CHANNEL CDI IGNITION			
Size	Number	Revision	
A4	SERIES 3	1.0	
Date:	18-Apr-2006	Sheet 1 of	1
File:	D:\M&W\Pro16_S3_1.sch	Drawn By:	M&W

M & W IGNITIONS

(C)1996 - 2006 M&W IGNITIONS

CAUTION!
HIGH VOLTAGE

DISCONNECT POWER BEFORE
WORKING ON UNIT

- * See page 1 instructions for trigger edge selection link
- ** Shielded cables required for Australian EMC compliance

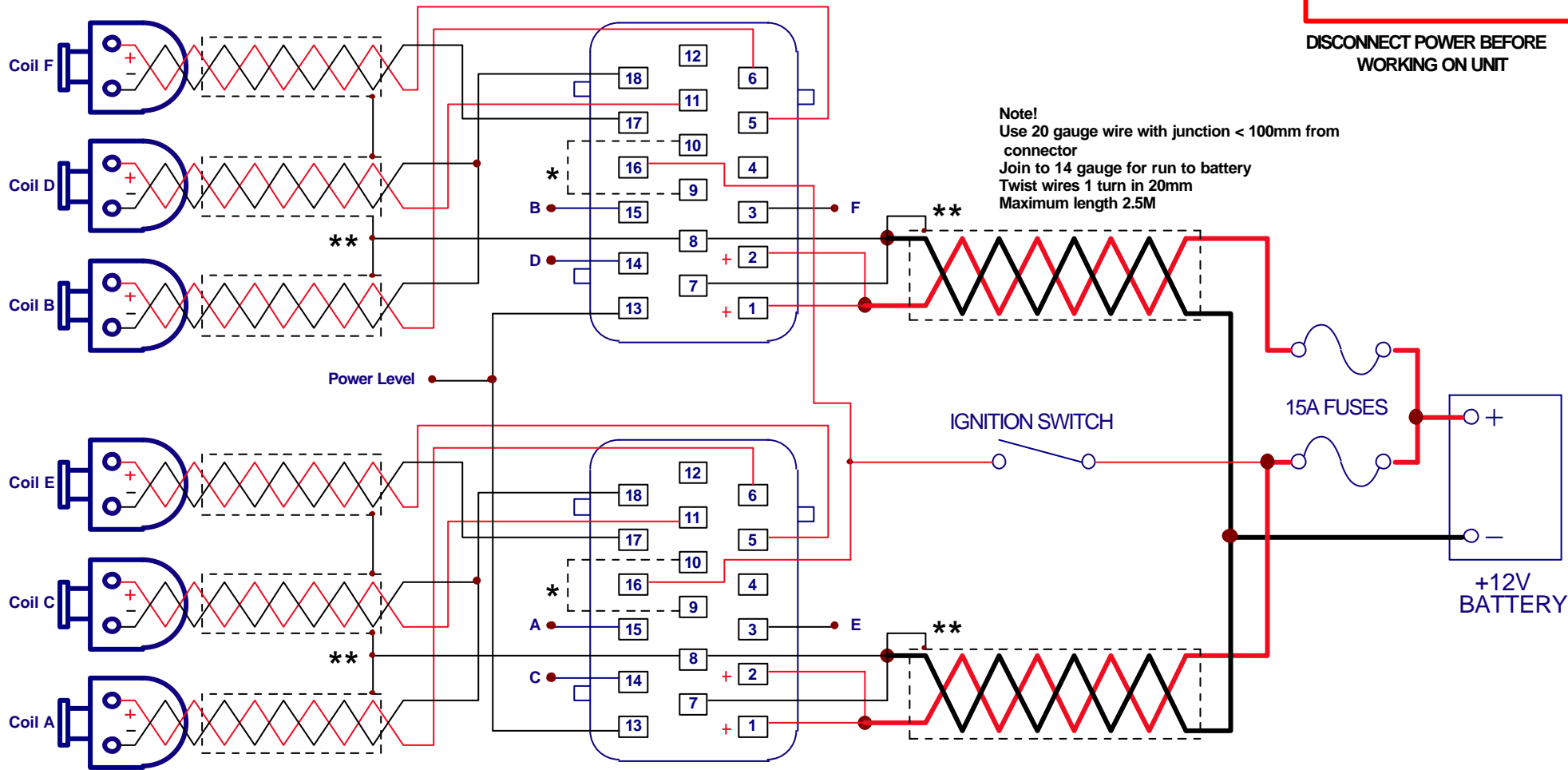

Note!
Use 20 gauge wire with junction < 100mm from connector
Join to 14 gauge for run to battery
Twist wires 1 turn in 20mm
Maximum length 2.5M

Note!
Use 18-20 gauge wire
Twist wires 1 turn in 20mm
Maximum wire length 2M

← TOP
CDI CONNECTOR
(LOOKING AT END
OF EXTRUSION)

Title			6 CHANNEL SEQUENTIAL IGNITION		
Size	Number	PRO-16 S3		Revision	1.0
A4					
Date:	18-Apr-2006	Sheet 1 of	1		
File:	D:\M&W\Pro16_S3_2.sch	Drawn By:	M&W		

M & W IGNITIONS

(C)1996 - 2006 M&W IGNITIONS

CAUTION!
HIGH VOLTAGE

DISCONNECT POWER BEFORE
WORKING ON UNIT

* See page 1 instructions for trigger edge selection link
** Shielded cables required for Australian EMC compliance

Note!
Use 20 gauge wire with junction < 100mm from connector
Join to 14 gauge for run to battery
Twist wires 1 turn in 20mm
Maximum length 2.5M

Note!
Use 18-20 gauge wire
Twist wires 1 turn in 20mm
Maximum wire length 2M

← TOP
CDI CONNECTOR
(LOOKING AT END
OF EXTRUSION)

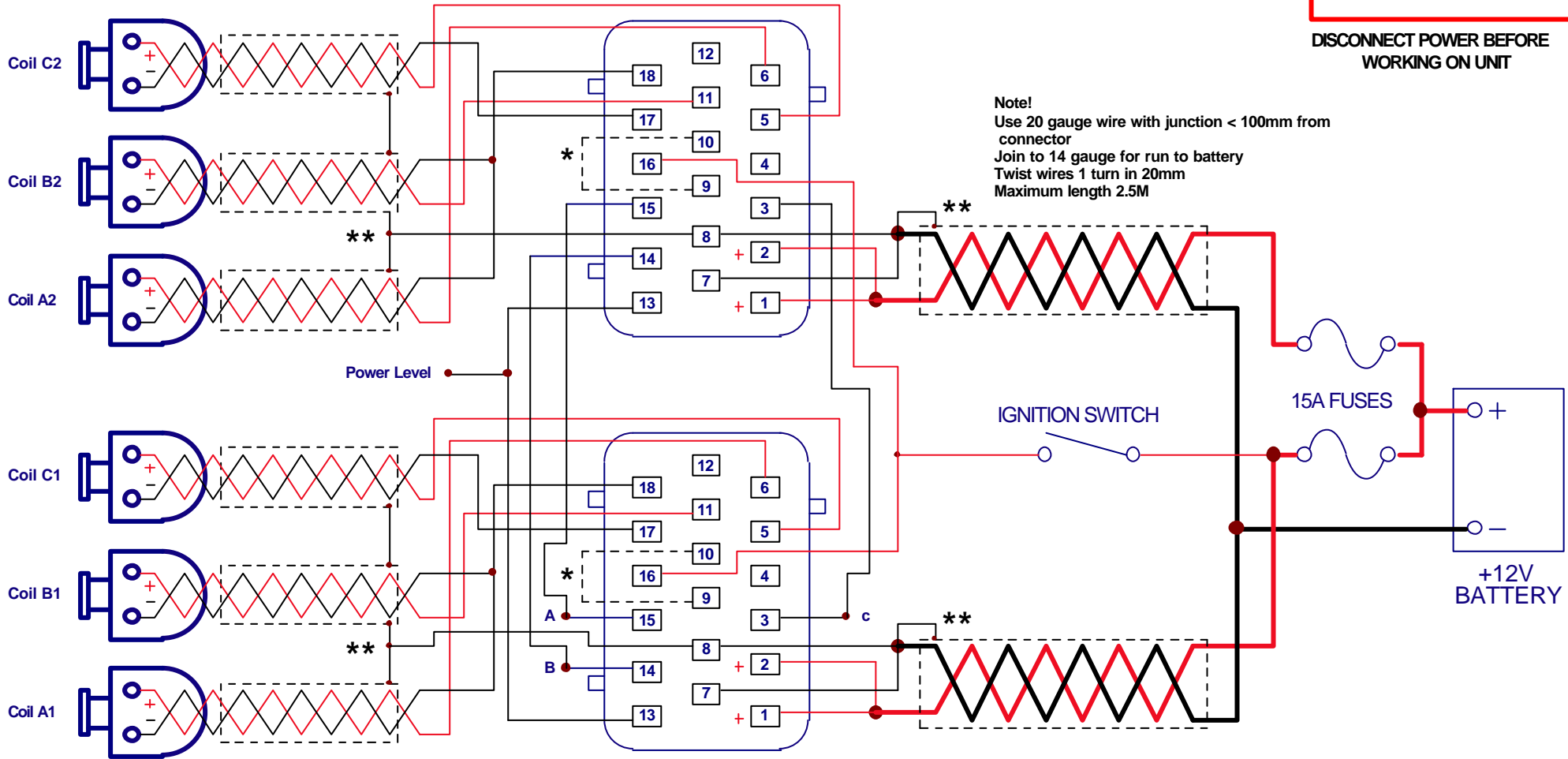

Title			6 CHANNEL WASTED SPARK IGNITION		
Size	Number	PRO-16 S3		Revision	1.0
A4					
Date:	18-Apr-2006	Sheet 1 of	1		
File:	D:\M&W\Pro16_S3_3.sch	Drawn By:	M&W		

M & W IGNITIONS

(C)1996 - 2006 M&W IGNITIONS

CAUTION!
HIGH VOLTAGE

DISCONNECT POWER BEFORE
WORKING ON UNIT

* See page 1 instructions for trigger edge selection link
** Shielded cables required for Australian EMC compliance

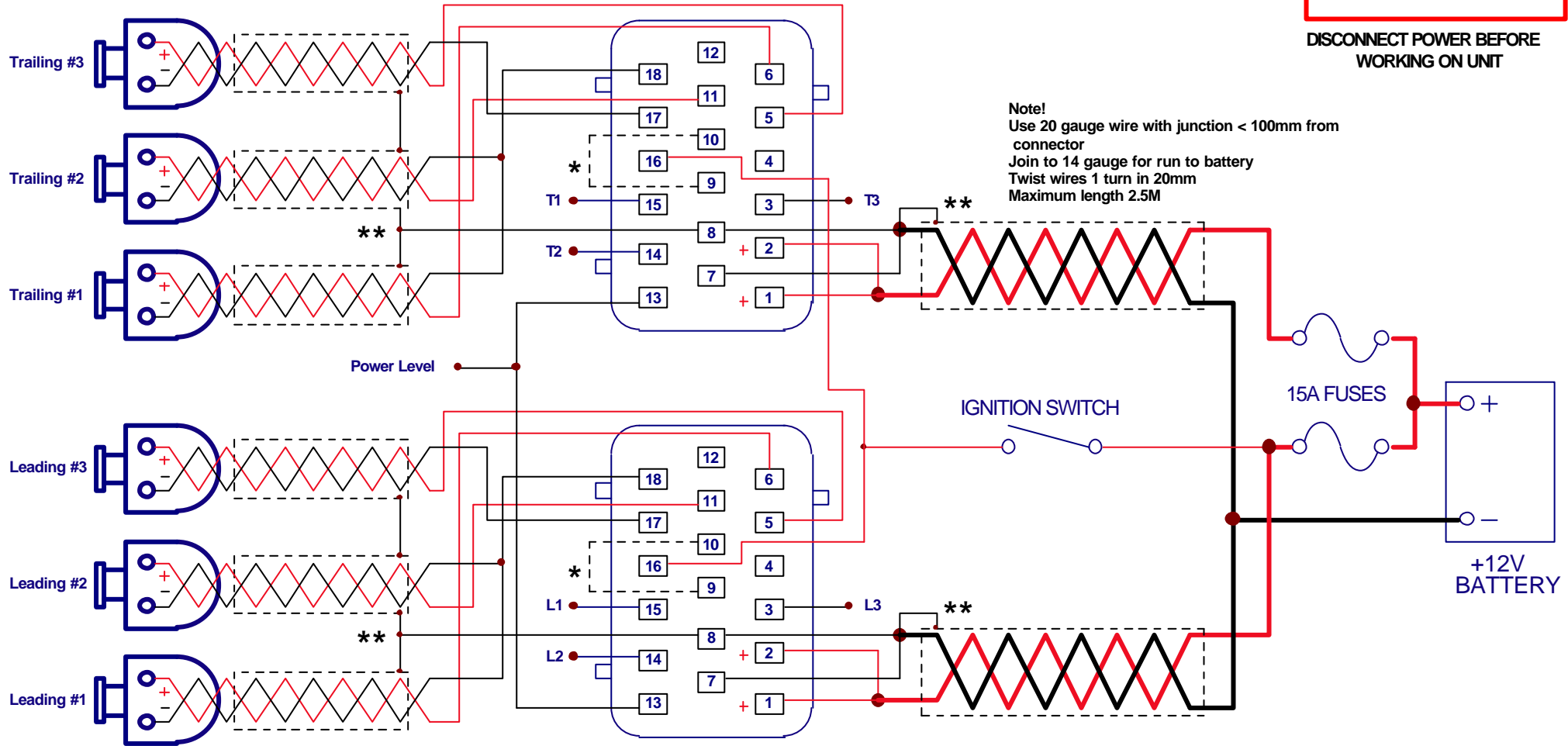

Note!
Use 20 gauge wire with junction < 100mm from connector
Join to 14 gauge for run to battery
Twist wires 1 turn in 20mm
Maximum length 2.5M

Note!
Use 18-20 gauge wire
Twist wires 1 turn in 20mm
Maximum wire length 2M

Title			MAZDA TRIPE ROTOR IGNITION		
Size	Number	PRO-16 S3		Revision	1.0
A4					
Date:	18-Apr-2006	Sheet 1 of	1		
File:	D:\M&W\Pro16_S3_4.sch	Drawn By:	M&W		